

EN/CN/DE/FR/한-A01

Creator 3 Pro / 金刚狼3 Pro

Quick Start Guide

≡ 快速启动指南 ≡

EN P01 / CN P09 / DE P17 / FR P25 / 한 P33

⚠ WARNING

1. Hot! Avoid touching the heating nozzle and heating build plate in operation.
2. Moving parts in printer may cause injury. Do not wear gloves or other sources of entanglement in operation.

⚠ 注意事项

1. 高温危险！打印机喷嘴和打印平台在工作时会被加热，请避免接触！
2. 可动部件可能造成卷入挤压和切割伤害。操作机器时请不要佩戴手套或缠绕物。

Creator 3 Pro Quick Start Guide

Creator 3 Pro Introduction

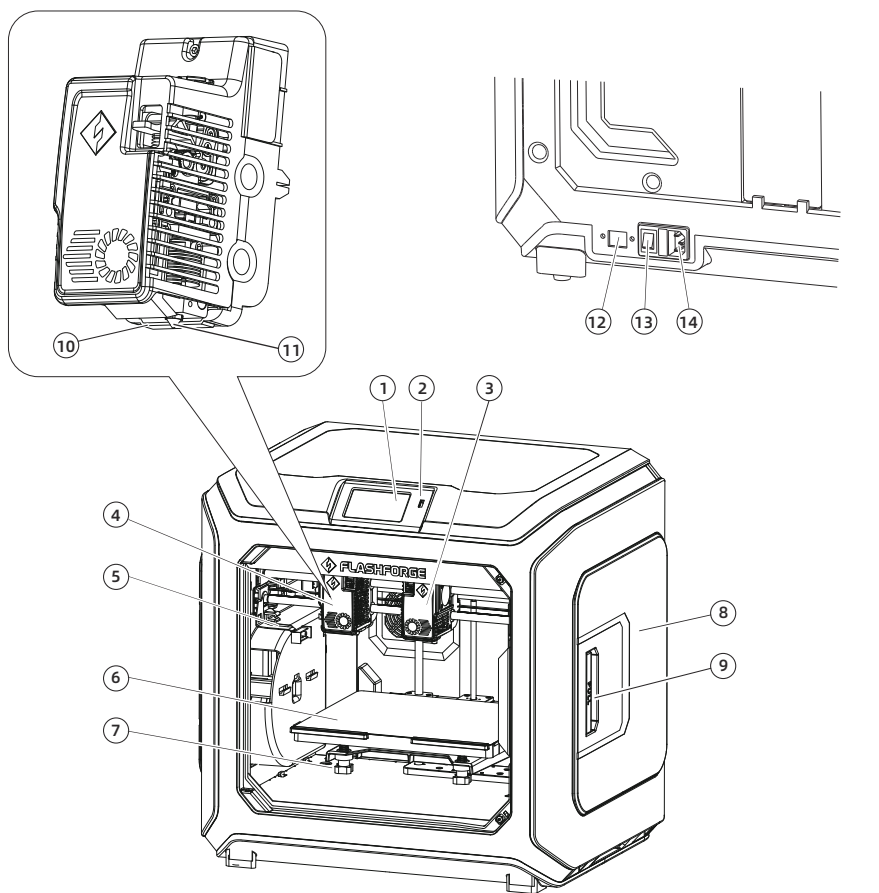

- 1. Touch screen
- 2. USB disk port
- 3. Right extruder
- 4. Left extruder
- 5. The anti-oozing metal plate

- 6. Build plate
- 7. Leveling nut
- 8. Filament holder cover
- 9. Filament holder cover handle
- 10. Wind guide nozzle

- 11. Nozzle
- 12. Ethernet port
- 13. Power switch
- 14. Power cord entry

Packing List

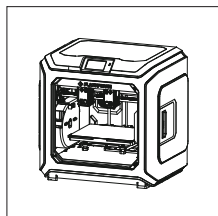

Creator 3 Pro

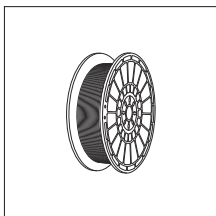

Filament

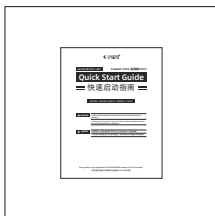

Quick Start Guide



After-sales
service card

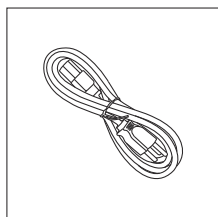

Power cord

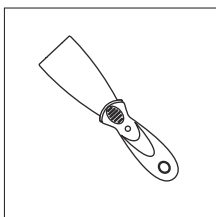

Scraper

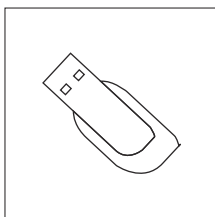

USB disk

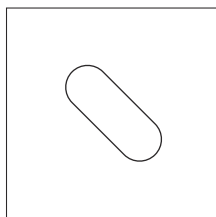

Leveling card

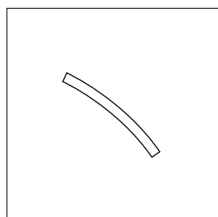

PTFE tube

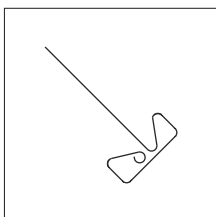

Unclogging pin tool

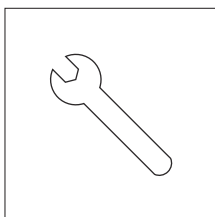

Stamping wrench

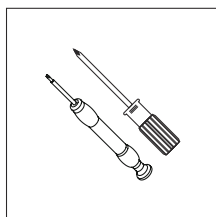

Screwdriver

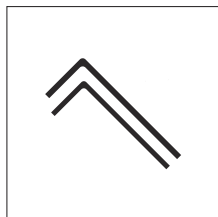

Allen wrench

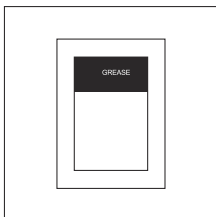

Lubricating grease

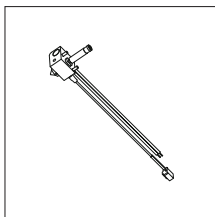

Nozzle kit

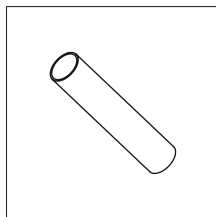

Nozzle support tube

Precautions for Unpacking the Equipment

1. Take out the top accessories and pearl cotton.
2. Remove the tape from the machine.
3. Take out the internal pearl cotton block.

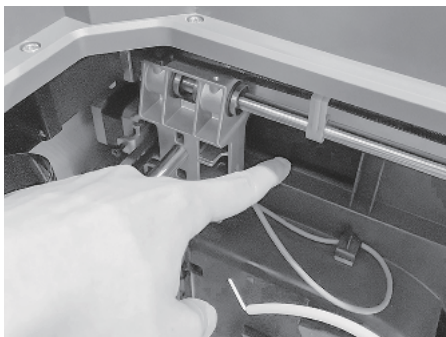
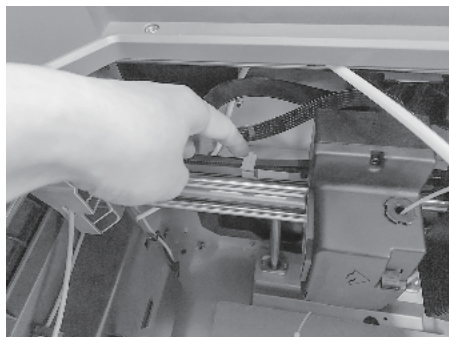

4. Remove the buckles on the X-axis and Y-axis synchronous belts.

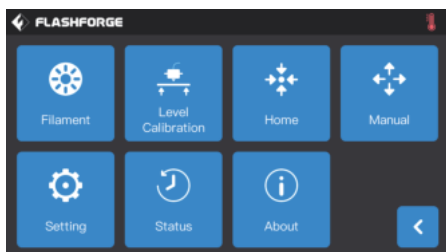

5. Connect the printer to the power supply, after power on, and then click [Tools] and [Manual] in turn on the touch screen to enter the manual control interface.



6. Press and hold [Z-] continuously until the build plate rises to a higher position, and then take out the foam block below.

Preparation for Printing

Filament Loading

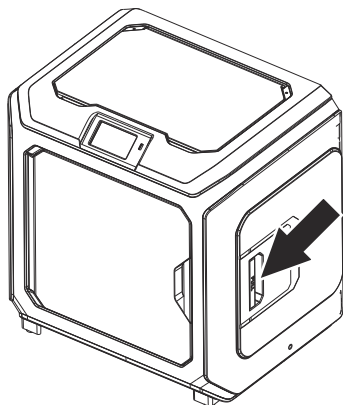

1. Open the filament holder cover.

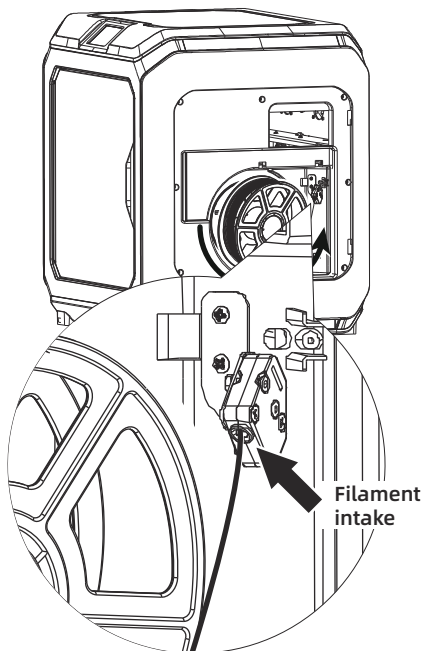

2. Take out the filament and insert it into the filament feeding inlet.

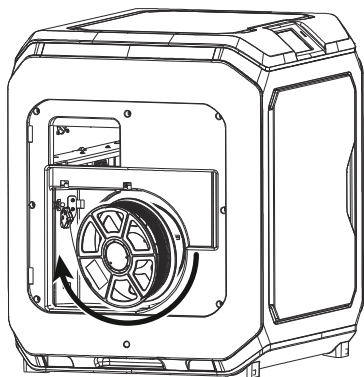

3. Attention: To facilitate smooth rotation of the filament, please install the filament in the direction shown in the figure.

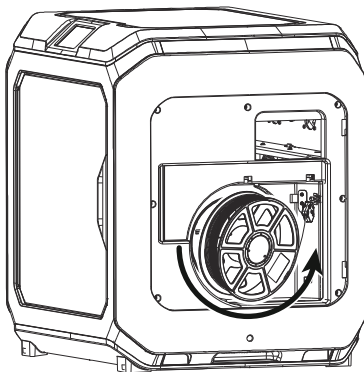

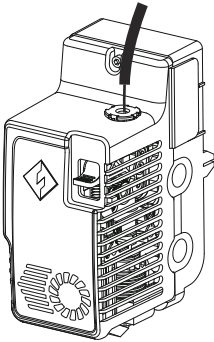

4. Insert the filament into the filament feeding inlet continuously until the filament goes through the filament guide tube.

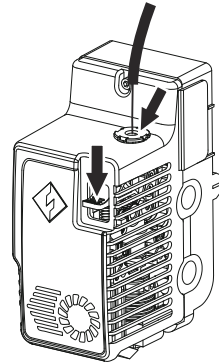

5. Press the filament feeding pressing plate in front of the extruder, insert the filament vertically into the extruder until it can't be inserted any further, and then loosen the filament feeding pressing plate.

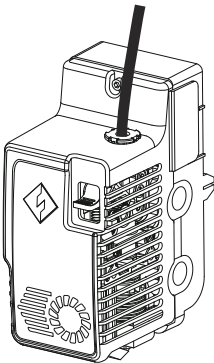

6. Insert the filament guide tube into the filament inlet hole on the extruder to fix.

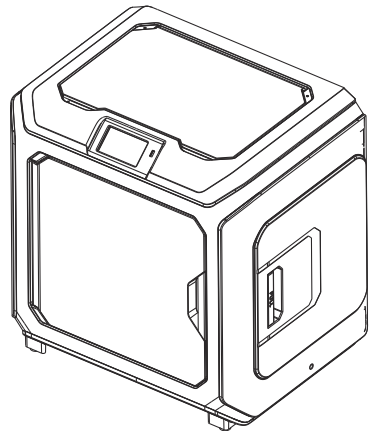

7. Finally, fix the filament spool on the filament spool holder and close the cover.

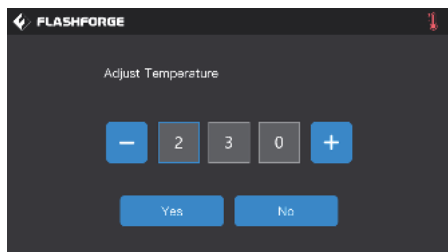
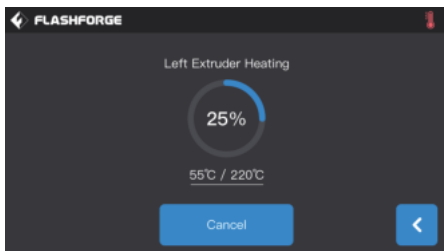
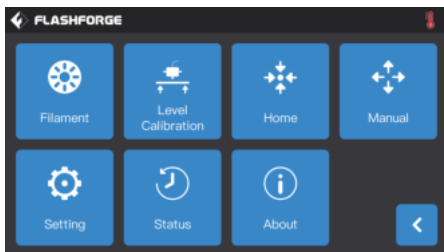
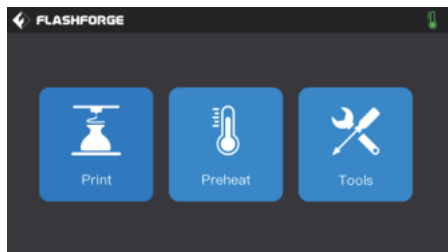

8. Filament feeding operation: Click the [Tools]-[Filament] button on the screen in turn, and set a reasonable heating temperature according to the required temperature value of the material; Operate according to the screen prompts, and wait for the nozzle to extrude uniform filament smoothly.

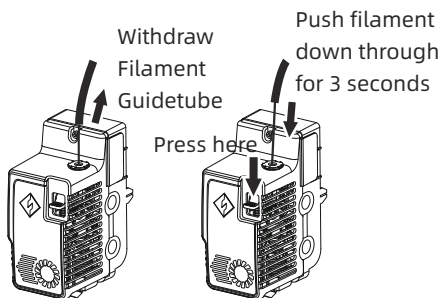
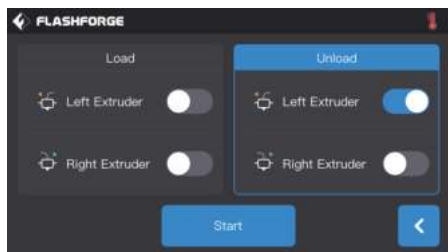

Filament unloading operation: Click [Unload], press down the filament pressing plate after the extruder temperature heating is completed, pull out the white filament guide tube, and pull out the filament upward quickly and then filament unloading is completed.

Leveling and Calibration

The equipment has been leveled and calibrated before leaving factory. However, the leveling plane may be damaged due to the vibration generated during transportation. It is recommended to perform leveling before the first printing. There are two leveling modes: auxiliary leveling mode and manual leveling mode. In the auxiliary leveling mode, all execution will be completed with the help of the extruder sensor and auxiliary prompts. When the function option is in the manual mode, the platform leveling in the auxiliary mode will not activate the sensor function.

In total, the equipment contains the following leveling calibrations: Platform Leveling, Calibration XY, Calibration Z and Auto level;

Please operate in the following order:

1. Click [Tools] and [Level Calibration] on the touch screen;
2. Select the auxiliary mode for leveling and calibration;
3. The extruder sensor calibration has been set before leaving factory, so there is no need to operate again; Click platform leveling and operate following the prompts on the screen;
4. Perform Z-axis calibration and operate following the prompts on the screen;
5. The X, Y axis have been calibrated before leaving factory, so there is no need to operate again;
6. The whole leveling and calibration is completed.

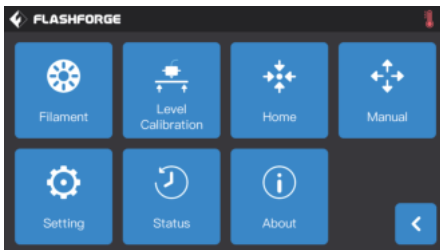

9-point leveling function: when the printing flatness is still poor after the platform leveling and XY/Z axis calibration, this function can be used to compensate for better flatness;



Manual leveling mode: Execute platform leveling, Z-axis calibration and X, Y axis calibration in turn. This is a complete set of leveling and calibration operation procedures.

First Print

Before the first printing, please complete the leveling, loading and calibration correctly under the guidance of the quick start guide.

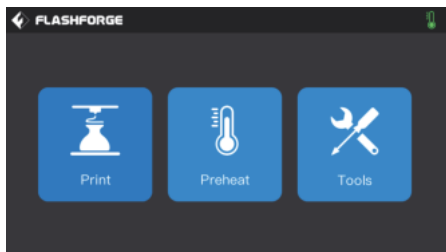

1. Tap [Print].

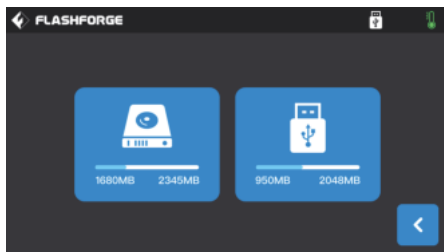

2. Tap [Local memory] to choose print files.

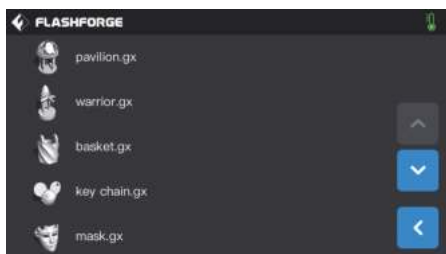

3. Choose the preset print file [pavilion.gx].

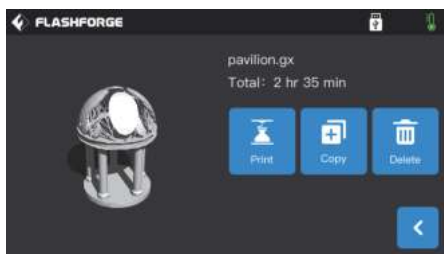

4. Tap [Print].

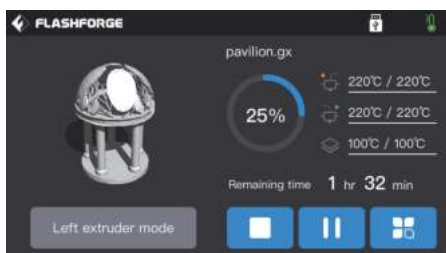

5. The printer starts to heat up and will start printing after heating completed.

金刚狼3 Pro 快速启动指南

整机介绍

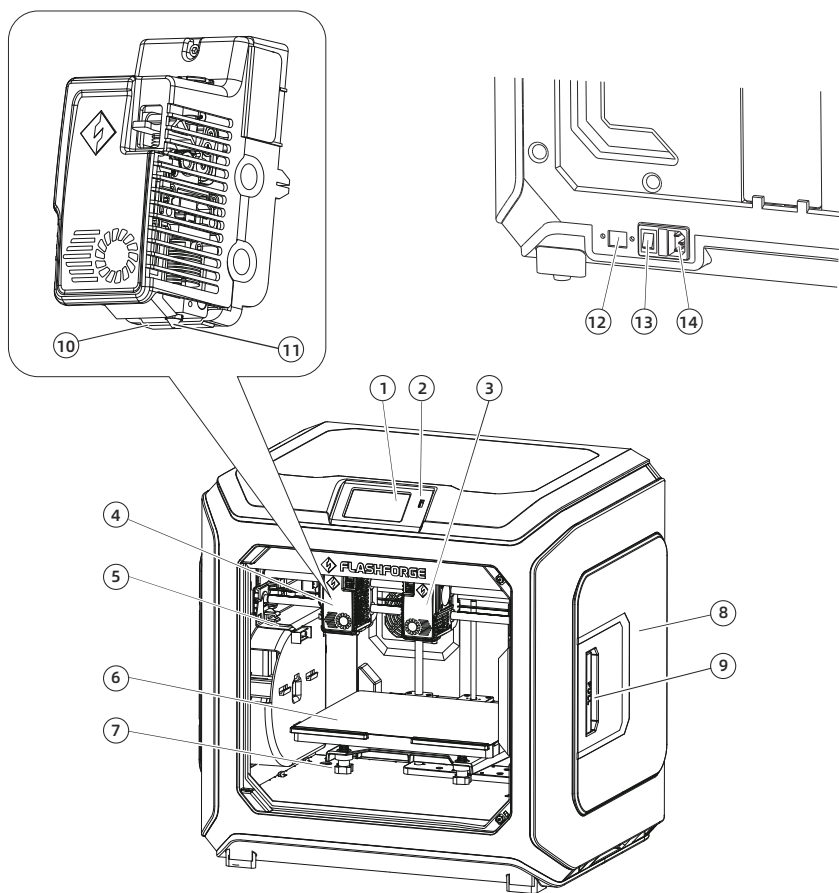

- | | | | |
|--------|----------|----------|----------|
| 1、触摸屏 | 5、金属防漏丝板 | 9、丝盘盖把手 | 13、电源开关 |
| 2、U盘端口 | 6、打印平台 | 10、导风嘴 | 14、电源线接口 |
| 3、右喷头 | 7、调平螺母 | 11、喷嘴 | |
| 4、左喷头 | 8、丝盘盖 | 12、以太网接口 | |

装箱清单

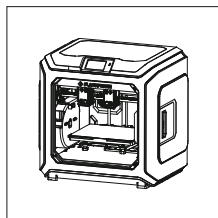

3D打印机

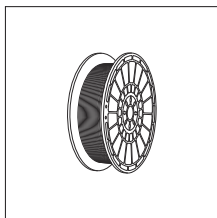

3D打印耗材

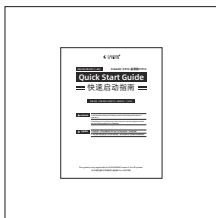

快速启动指南



售后服务卡

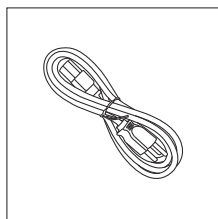

电源线

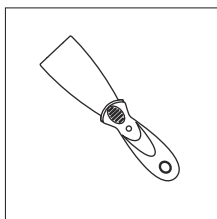

铲刀

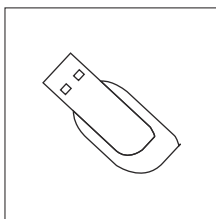

U盘

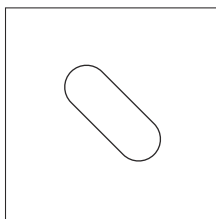

调平卡

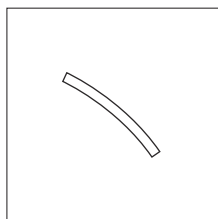

聚四氟乙烯管

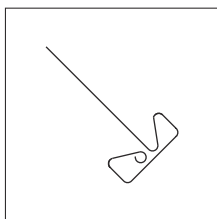

通针

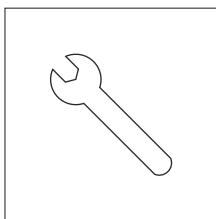

冲压扳手

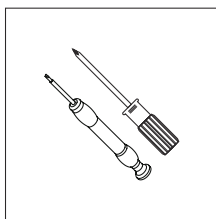

螺丝刀

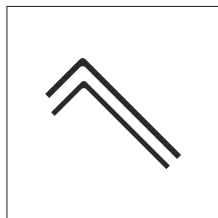

内六角扳手

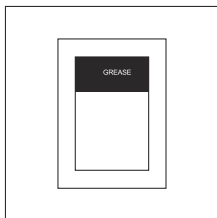

润滑脂

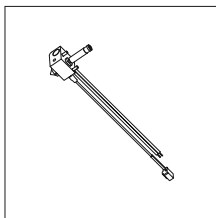

喷嘴组件

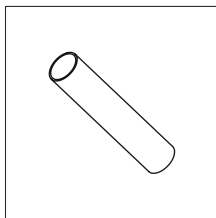

喷嘴支撑管

设备开箱的注意事项

1. 取出顶部配件与珍珠棉;
2. 移除机身上的胶带;
3. 取出内部的珍珠棉块;

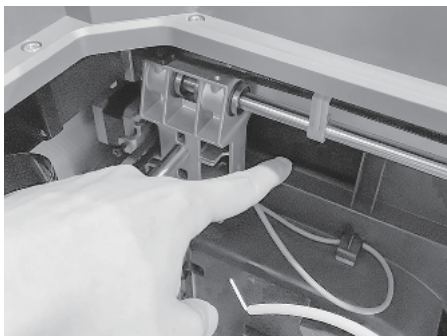
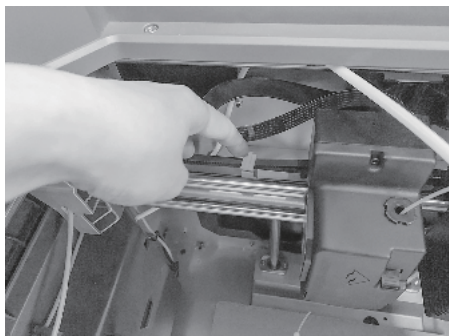

4. 移除X轴、Y轴同步带上的卡扣;



5. 打印机连接电源, 开机后, 在触摸屏上依次点击【工具】、【手动调节】进入手动控制界面;



6. 持续按住【Z-】, 直到打印平台上升到较高的位置, 取出下方的泡沫块。

打印前准备

安装丝料

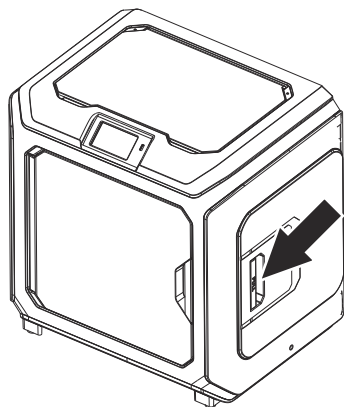

1. 打开丝盘盖。

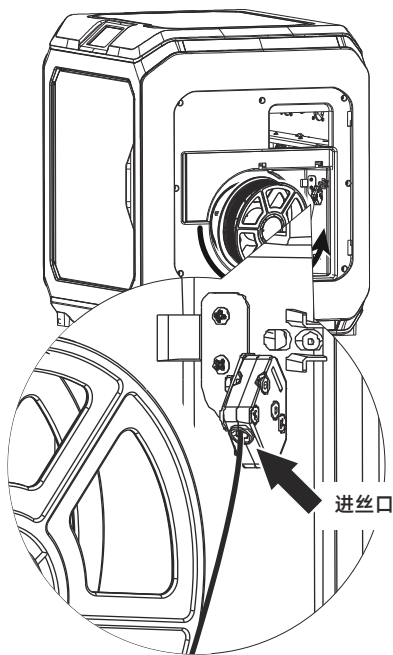

2. 取出耗材，将耗材插入进丝口中。

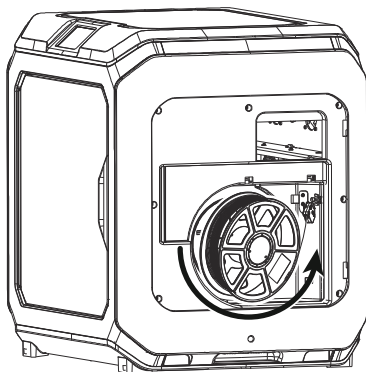
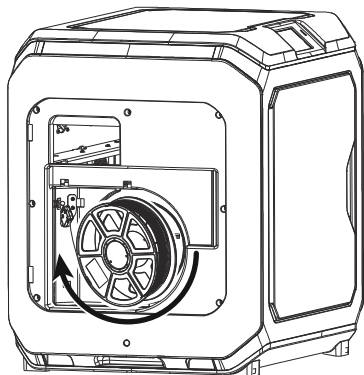

3. 注意：为方便耗材转动顺畅，请按图中所示的方向安装耗材。

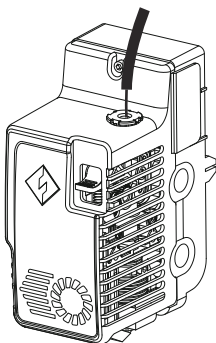

4. 持续将耗材送入进丝口，直到耗材从导丝管穿出。

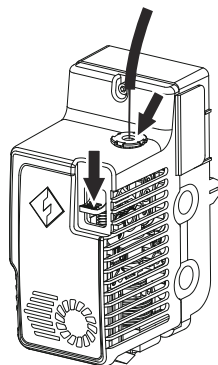

5. 按下喷头前方的进丝压板，将耗材垂直插入入喷头，直到无法继续插入。松开进丝压板。

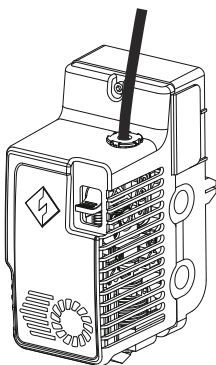

6. 将导丝管插入喷头进丝孔中固定。

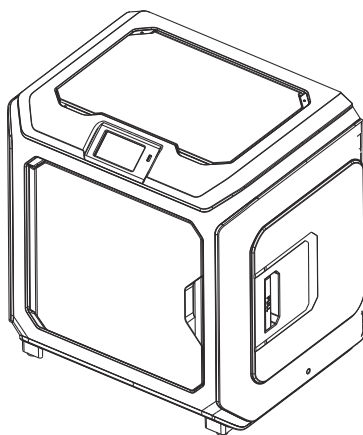

7. 最后将丝盘固定在丝盘架上，盖上丝盘盖。



8. 进丝操作：点击屏幕中的【工具】-【换丝】按钮，根据材料所需温度值设置合理加热温度；根据屏幕提示进行操作，等待喷嘴挤出均匀的耗材。

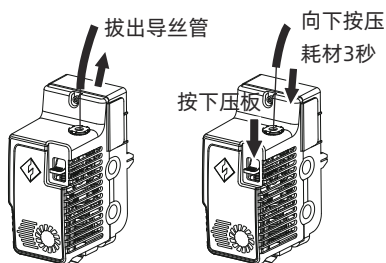

退丝操作：点击【退丝】，待喷头温度加热完成后，向下压耗材压板，拔出白色耗材导丝管，将耗材迅速向上拔出，退丝完成。

调平与校准

设备出厂已进行过调平校准，由于运输中会产生震动，调平面可能会被破坏，建议首次打印前进行一次调平。调平方式有两种模式：辅助调平模式和手动调平模式。在辅助调平模式下，所有执行将借助喷头传感器及辅助提示完成。

当功能选项在手动模式时，辅助模式中的平台调平将不启动传感器功能。

设备总共包含如下调平校准：平台调平，XY校准，Z轴校准，9点调平；

按如下顺序进行操作：

1. 在触控屏上点击【工具】、【调平与校准】；
2. 选择辅助模式进行调平校准；
3. 喷头传感器校准已在出厂前完成设定，无需再操作；点击平台调平，按照屏幕提示进行操作；
4. 进行Z轴校准，按屏幕提示进行操作；
5. X.Y轴在出厂前已经完成校准，无需再操作；
6. 整个调平校准完成。



9点调平功能：在平台调平以及XY/Z轴校准后，打印平面度仍较差时，可以使用该功能进行补偿，以获得更好的平面度；



手动调平模式：依次执行平台调平、Z轴校准、XY轴校准。此为一套完整的调平校准操作流程。

首次打印

首次打印前，请在快启的指引下正确地完成调平、进丝和校准。

打印建议

1. 打印开始前请确保打印机已经经过调平；
2. 打印开始前确保耗材安装正确，没有打结或卡住；
3. 喷头内可能残留有少量耗材，请进丝一段时间，确保上一次打印的耗材已经全部挤出；
4. 使用ABS耗材打印时，请装上顶罩，关闭前门；使用PLA耗材打印时，请移除顶罩，打开前门；
5. 打印开始前请将喷头耗材清理干净；
6. 不可在长时间无人看守的情况下使用3D打印机。



1. 点击 [打印]。

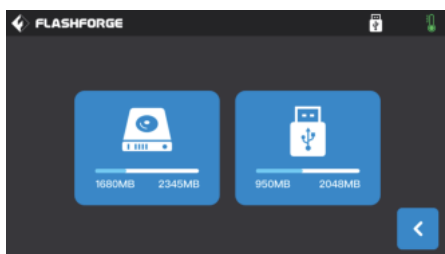

2. 点击 [内部储存] 进入打印模型选择界面。

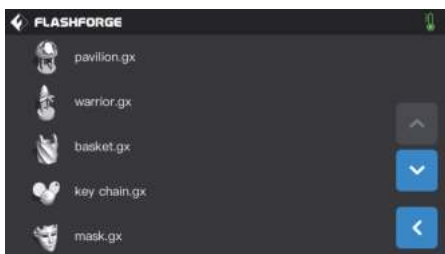

3. 选择预设文件 [pavilion.gx]。



4. 点击 [打印]。



5. 打印机开始加热，加热完成后开始打印。

Creator 3 Pro Kurzanleitung

Vorstellung von Creator 3 Pro

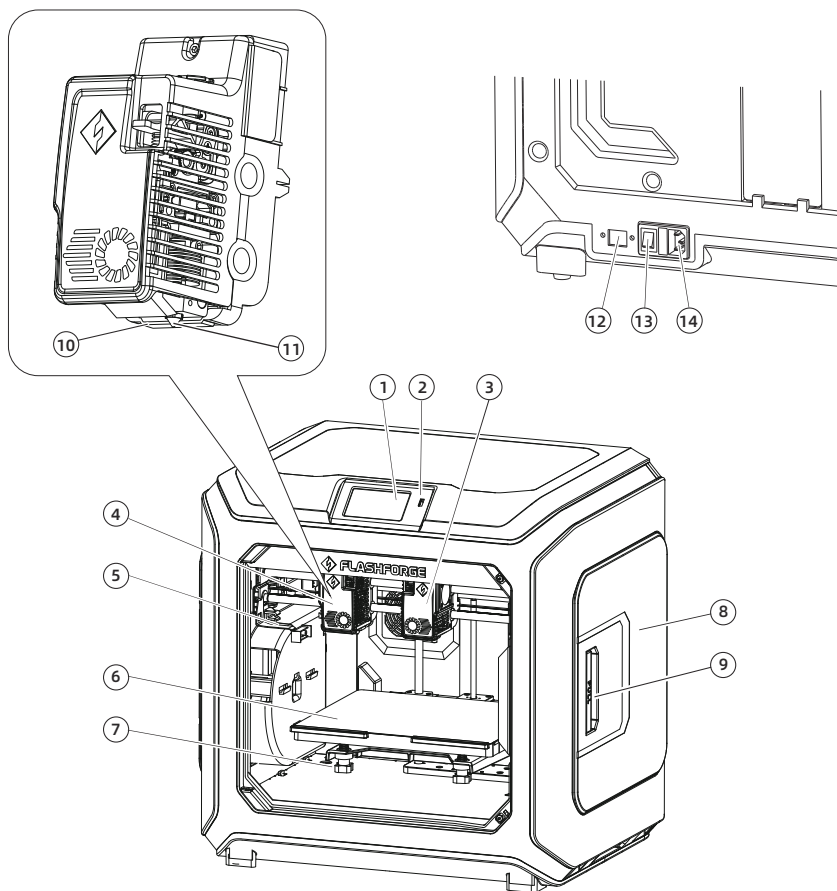

- | | | |
|--------------------------------|-----------------------------|-------------------------|
| 1. Touchscreen | 6. Konstruktionsplattform | 11. Düse |
| 2. USB-Anschluss | 7. Nivelliermutter | 12. Ethernet-Anschluss |
| 3. Rechter Extruder | 8. Filamenthalterabdeckung | 13. Netzschalter |
| 4. Linker Extruder | 9. Griff der Fadenabdeckung | 14. Stromkabelanschluss |
| 5. Auslaufsichere Metallplatte | 10. Führungsnase | |

Verpackungsinhalt

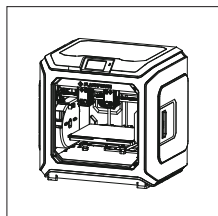

Creator 3 Pro

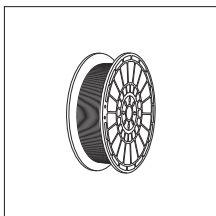

Filament

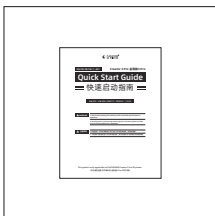

Kurzanleitung



Kundendienstkarte

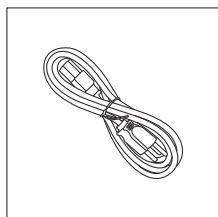

Stromkabel

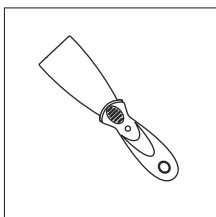

Abstreifer

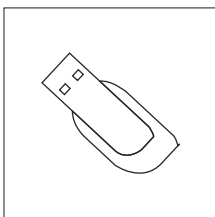

USB-Disk

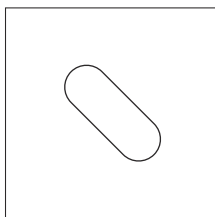

Nivellierkarte

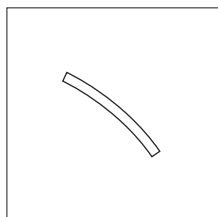

PTFE-Rohr

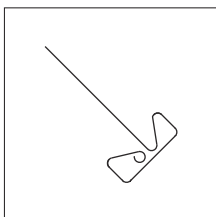

**Reinigungsstift-
werkzeug**

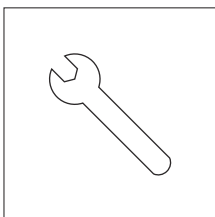

Stanzschlüssel

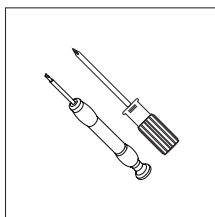

Schraubenzieher

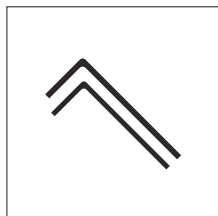

**Innensech-
kantschlüssel**

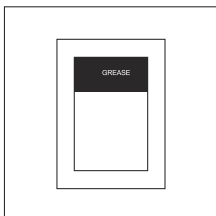

Schmierfett

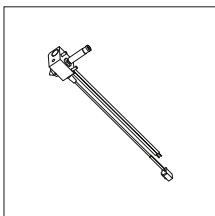

Düsenmontage

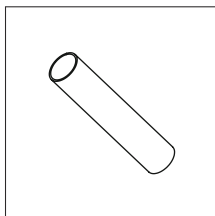

Düsenstützrohr

Warnhinweise zum Auspacken des Gerätes

1. Nehmen Sie das obenliegende Zubehör und das Baumwollperlgarn heraus.
2. Lösen Sie das Band vom Gerät.
3. Nehmen Sie den inneren Baumwollperlgarnblock heraus.

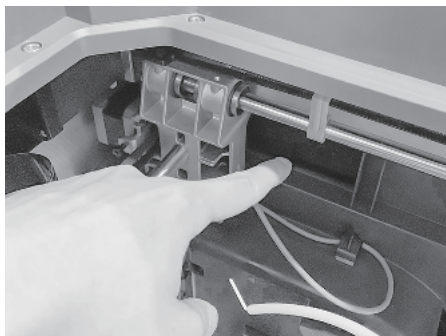
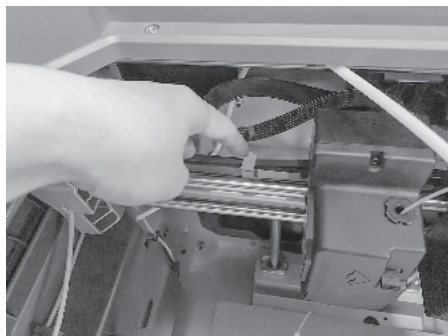

4. Entfernen Sie die Schnallen an den Synchrongurten der X-Achse und der Y-Achse.

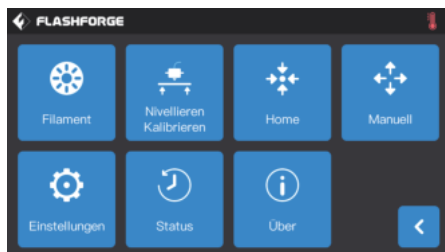

5. Verbinden Sie den Drucker mit der Stromversorgung. Tippen Sie nach dem Einschalten nacheinander auf dem Touchscreen auf [Tools] und [Manuell], um auf die manuelle Steuerschnittstelle zuzugreifen.

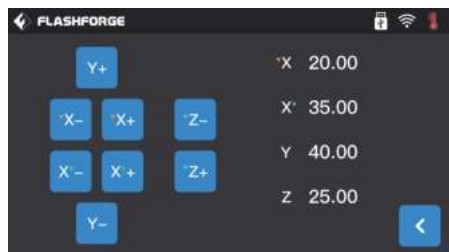

6. Halten Sie [Z-] angetippt, bis sich die Konstruktionsplattform anhebt. Nehmen Sie dann den Schaumstoffblock darunter heraus.

Druckvorbereitung

Filament laden

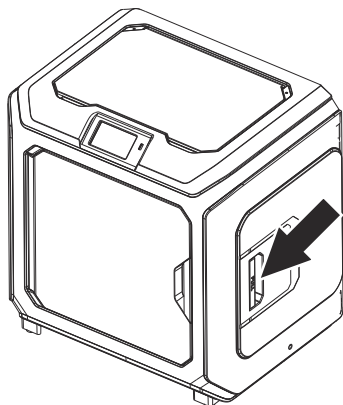

1. Öffnen Sie die Abdeckung des Filamenthalters.

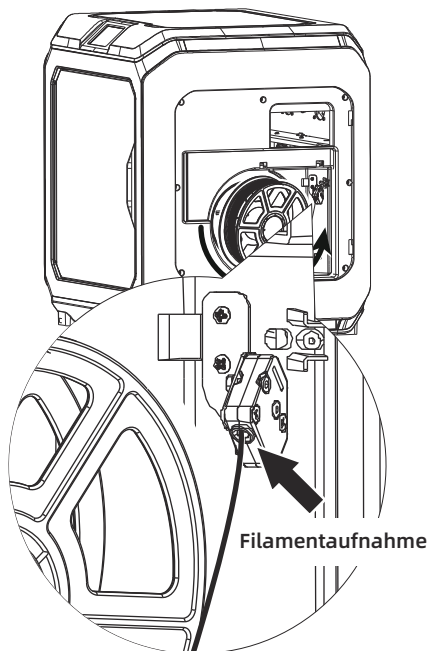

2. Nehmen Sie das Filament heraus und führen Sie es durch die Filamentzuführung.

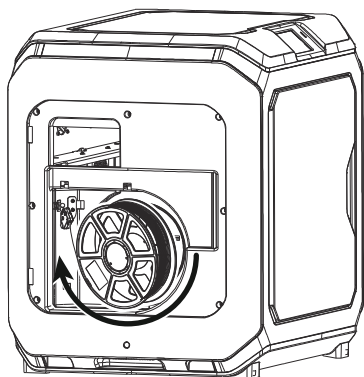

3. Achtung: Setzen Sie das Filament bitte in der auf der Abbildung gezeigten Richtung ein. Das vereinfacht die reibungslose Drehung des Filaments.

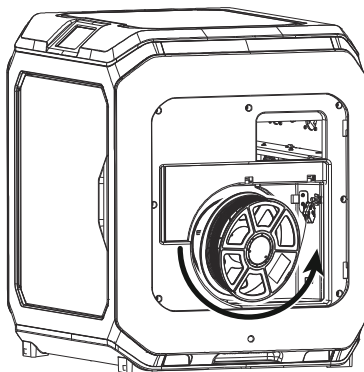

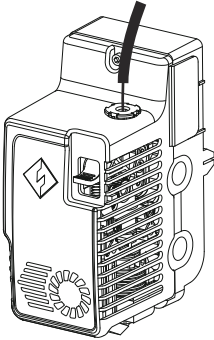

4. Setzen Sie das Filament ohne Unterbrechung in die Filamentzuführung ein, bis das Filament durch das Filamentführungsrohr geführt wird.

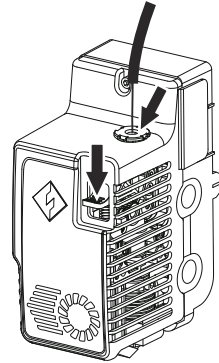

5. Drücken Sie die Filamentzuführung-Andrückplatte vor dem Extruder. Führen Sie das Filament vertikal bis zum Anschlag in den Extruder ein. Lösen Sie dann die Filamentzuführung-Andrückplatte.

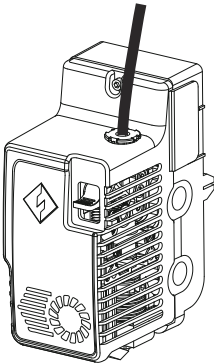

6. Führen Sie das Filamentführungsrohr in die Filamenteinführöffnung am Extruder ein, um es zu befestigen.

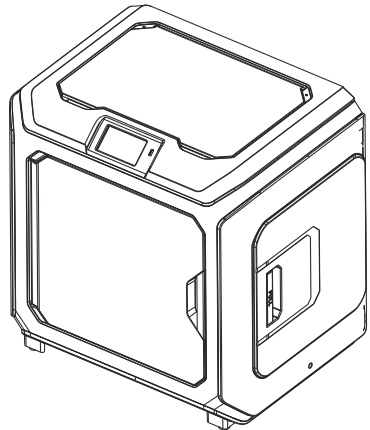

7. Befestigen Sie abschließend die Filamentspule am Filament-Spulenhalter und schließen Sie die Abdeckung.

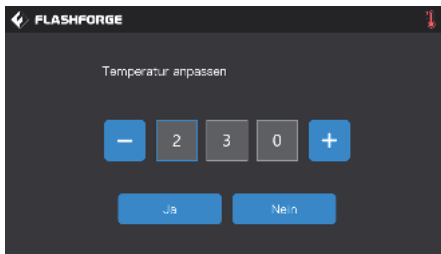
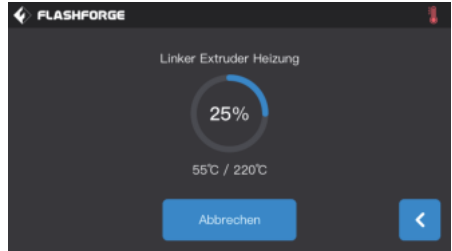
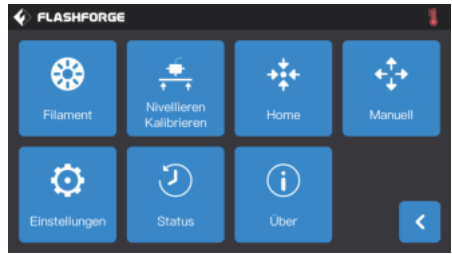
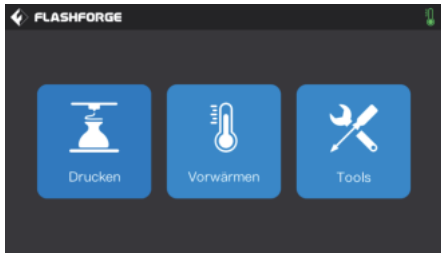

8. Laden: Tippen Sie nacheinander auf die Schaltflächen [Tools]-[Filament] auf dem Bildschirm. Legen Sie die Heiztemperatur gemäß dem benötigten Temperaturwert für das Material fest. Befolgen Sie die Anweisungen auf dem Bildschirm und warten sie, bis das Filament reibungslos aus der Düse austritt.

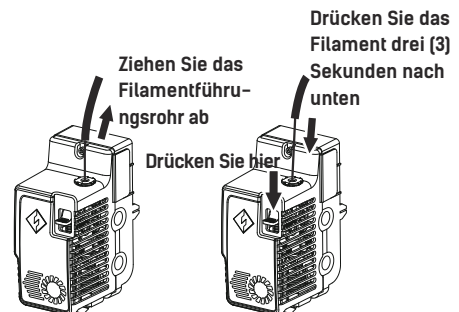

Entladen: Tippen Sie auf [Entladen], drücken Sie die Filament-Andrückplatte herunter, sobald die richtige Extrudertemperatur erreicht ist. Ziehen Sie das weiße Filamentführungsrohr herunter und ziehen Sie das Filament schnell nach oben. Dann ist das Entladen des Filaments abgeschlossen.

Nivellierung und Kalibrierung

Das Gerät wurde vor dem Versand ab Werk nivelliert und kalibriert. Die Nivellierebene kann jedoch infolge von Vibrationen während des Transports beschädigt sein. Es wird eine Nivellierung vor dem ersten Druck empfohlen. Es gibt zwei Nivelliermodi: Hilfsnivellierung und manuelle Nivellierung. Im Modus „Hilfsnivellierung“ werden alle Vorgänge mithilfe des Extrudersensors und unterstützenden Eingabeaufforderungen ausgeführt. Im manuellen Modus aktiviert die Plattformnivellierung im Hilfsmodus keine Sensorfunktion.

Insgesamt ermöglicht das Gerät die folgenden Nivellierkalibrierungen: Bettnivellierung, XY Kalibrierung, Z Kalibrierung und 9-Punkt-Nivellierung.

Behalten Sie bitte die folgenden Reihenfolge bei:

1. Tippen Sie auf dem Touchscreen auf [Tools] und [Nivellieren Kalibrieren].
2. Wählen Sie den Hilfsmodus für die Nivellierung und Kalibrierung.
3. Der Extrudersensor wurde vor dem Versand im Werk kalibriert und muss nicht erneut kalibriert werden. Tippen Sie auf die Plattformnivellierung und befolgen Sie die Bildschirmanweisungen.
4. Nehmen Sie die Kalibrierung der Z-Achse vor und befolgen Sie die Eingabeaufforderungen auf dem Bildschirm.
5. Die X- und Y-Achsen wurden ab Werk kalibriert. Sie müssen daher nicht erneut kalibriert werden.
6. Der gesamten Nivellier- und Kalibriervorgang ist abgeschlossen.

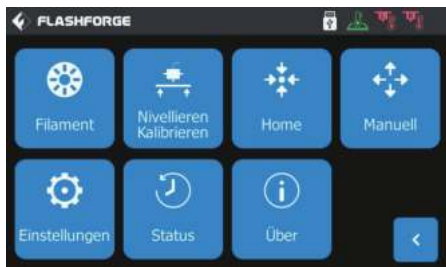

9-Punkt-Nivellierung: Wenn die Flachheit des Druckers nach der Plattformnivellierung und XY/Z-Achskalibrierung weiterhin nicht zufriedenstellend ist, kann diese Funktion verwendet werden, um die Flachheit zu verbessern.



Manuelle Nivellierung: Führen Sie nacheinander die Plattform-Nivellierung, Z-Achskalibrierung und die X-/Y-Achskalibrierung durch. Es handelt sich um einen kompletten Satz der Nivellierung- und Kalibriervorgänge.

Erster Druck

Vor dem ersten Druck schließen Sie bitte die Nivellierung, das Beladen und die Kalibrierung ab. Ziehen Sie die Schnellstartanleitung hinzu.

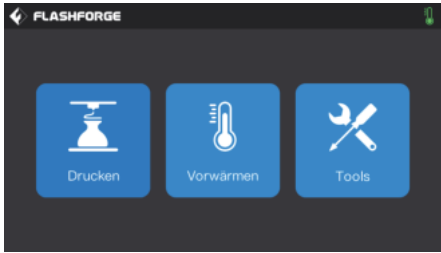

1. Berühren Sie [Drucken] (Konstruktion).

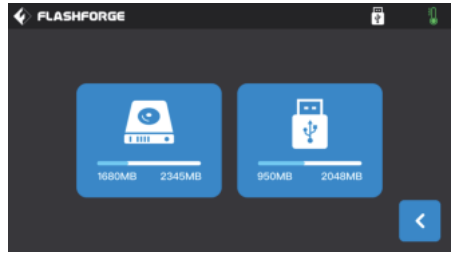

2. Berühren Sie [Local memory] (Lokaler Speicher) für die Auswahl der Druckdateien.

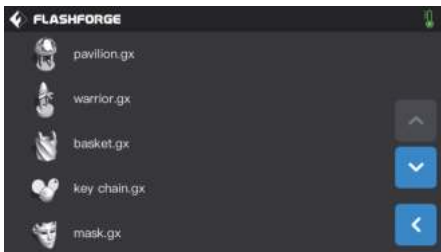

3. Wählen Sie die vorhandene Druckdatei.



4. Berühren Sie [Drucken] (Konstruktion).



5. Der Drucker wird aufgewärmt und startet den Druck nach dem Ende der Aufwärmphase.

Creator 3 Pro Guide rapide

Présentation de la Creator 3 Pro

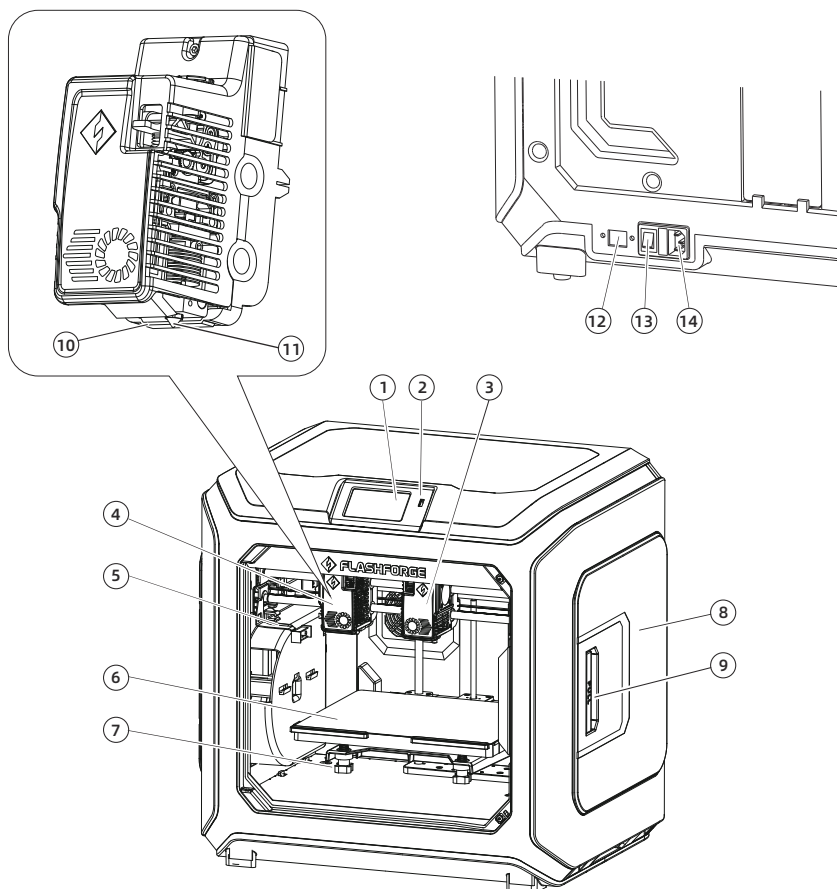

- | | |
|----------------------------|--|
| 1. Écran tactile | 8. Carter du porte-filament |
| 2. Port pour disque USB | 9. Poignée du carter du porte-filament |
| 3. Extrudeuse de droite | 10. Buse du déflecteur d'air |
| 4. Extrudeuse de gauche | 11. Buse |
| 5. Plaque anti-pénétration | 12. Port Ethernet |
| 6. Plateau | 13. Interrupteur marche/arrêt |
| 7. Écrou de nivellement | 14. Entrée du cordon d'alimentation |

Contenu de l'emballage

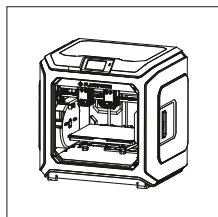

Creator 3 Pro

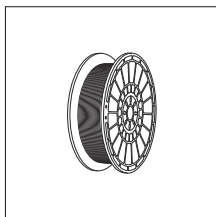

Filament

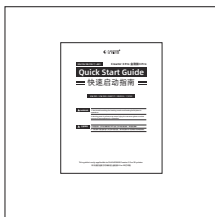

Guide rapide



**Carte de service
après-vente**

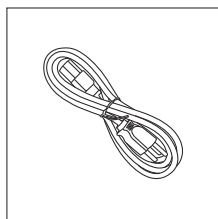

**Cordon
d'alimentation**

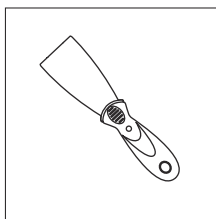

Grattoir

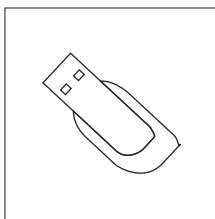

Disque USB

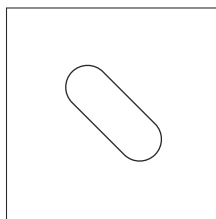

**Carte de
nivellement**

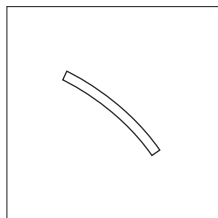

Tube en PTFE

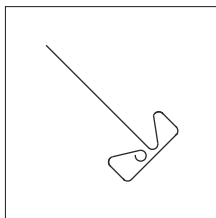

**Poinçon de
décolmatage**

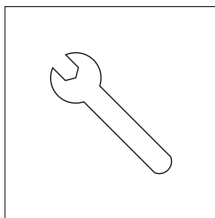

Clé en acier plat

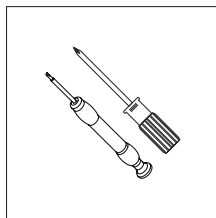

Tournevis



Clé Allen

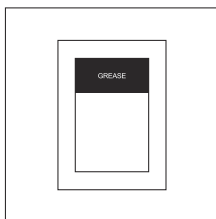

Graisse lubrifiante

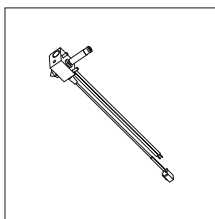

Ensemble de buse

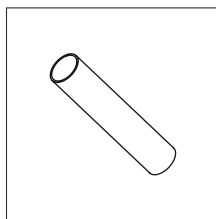

**Tuyau de support
pour buse**

Précautions à prendre lors du déballage

1. Retirez les accessoires du dessus et le coton perlé.
2. Décollez le ruban adhésif de la machine.
3. Sortez le bloc de coton perlé de l'intérieur.

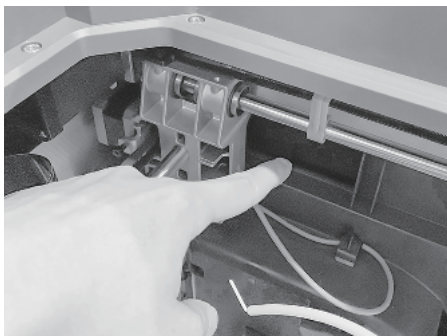
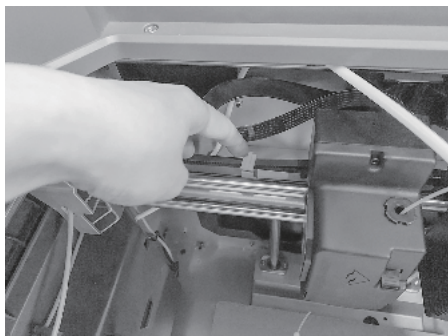

4. Retirez les attaches des courroies synchrones des axes X et Y.

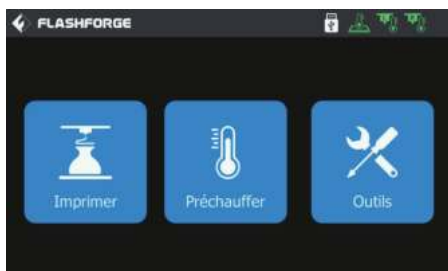

5. Branchez l'imprimante sur le secteur, allumez-la et cliquez sur [Outils] puis sur [Manuel] sur l'écran tactile pour entrer à l'interface de commande manuelle.

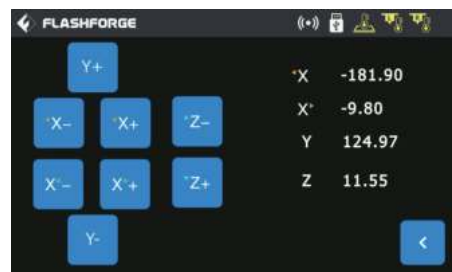

6. Appuyez longuement sur [Z-] jusqu'à ce que le plateau atteigne sa position la plus haute, puis retirez le bloc de mousse du dessus.

Préparation à l'impression

Chargement du filament

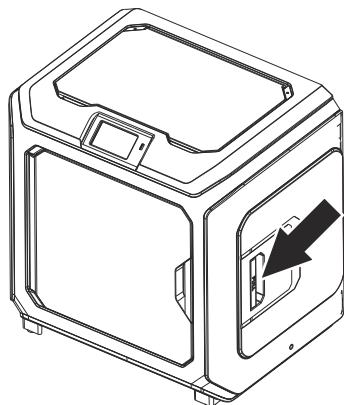

1. Ouvrez le carter du porte-filament.

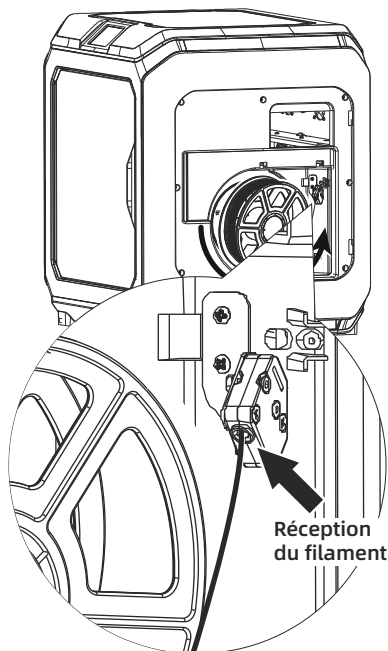

2. Tirez sur le filament et insérez-le dans l'entrée d'alimentation en filament.

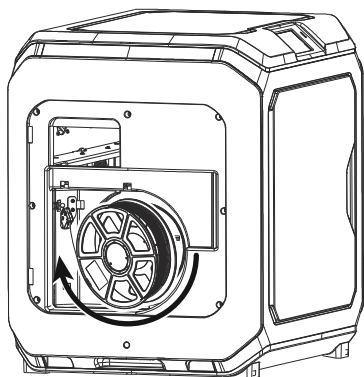

3. Attention : Pour faciliter la rotation libre du filament, installez celui-ci dans la direction illustrée.

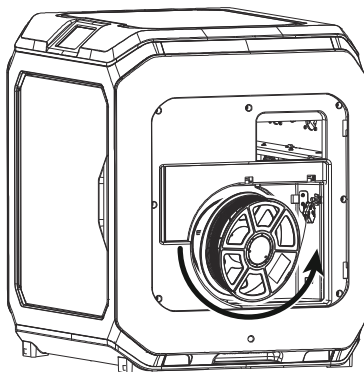

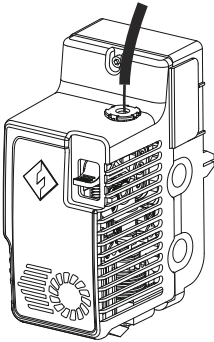

4. Continuez l'insertion du filament dans l'entrée d'alimentation en filament jusqu'à ce qu'il ait traversé le tube de guidage.

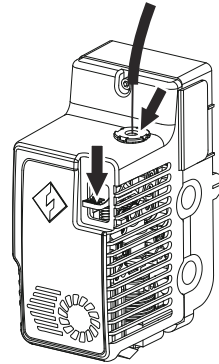

5. Appuyez sur la plaque de pression de l'alimentation en filament située à l'avant de l'extrudeuse, insérez le filament verticalement dans l'extrudeuse jusqu'à ce qu'il bute, puis libérez la plaque de pression.

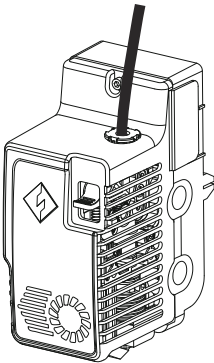

6. Insérez le tube de guidage du filament dans le trou d'entrée de l'extrudeuse pour le fixer.

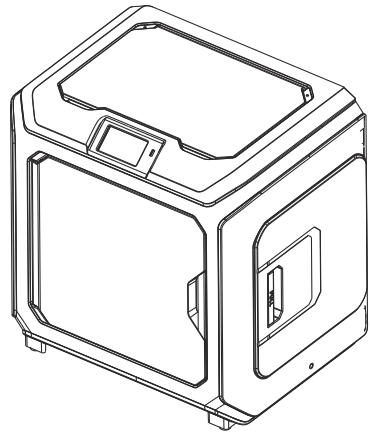

7. Enfin, fixez la bobine de filament sur le porte-filament et fermez le carter.

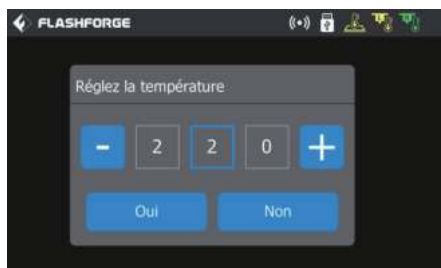
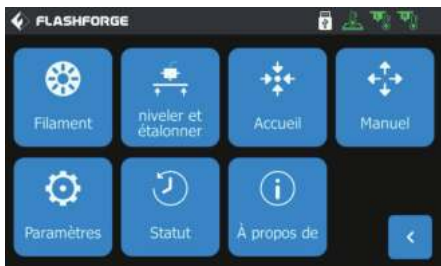
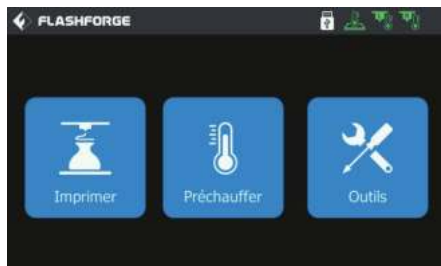

8. Alimentation en filament : cliquez successivement sur les boutons [Outils]-[Filament] de l'écran, puis définissez une température de chauffage raisonnable conformément à la température requise par le matériau. Suivez les invites qui s'affichent, et attendez que la buse extrude sans heurts un filament uniforme.

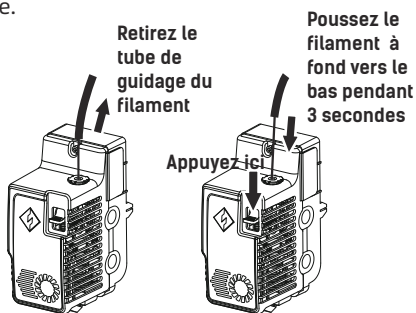

Déchargement du filament : cliquez sur [Décharger], appuyez sur la plaque de pression du filament une fois que l'extrudeuse a atteint la température de consigne, tirez sur le tube de guidage blanc du filament pour le retirer, puis tirez rapidement le filament vers le haut. Le déchargement est alors terminé.

Nivellement et étalonnage

L'appareil a été nivelé et étalonné en usine. Cependant, le plan de nivellement peut s'être modifié à cause de vibrations pendant le transport. Il est conseillé d'effectuer un nivellement avant la première impression. Il y a deux modes de nivellement : le mode auxiliaire et le mode manuel. Dans le mode auxiliaire, tout se fera avec l'aide du capteur de l'extrudeuse et des invites auxiliaires. Si l'option de fonction est en mode manuel, le nivellement de la plateforme en mode auxiliaire n'active pas la fonction du capteur.

L'appareil demande les étalonnages de nivellement suivants : Nivellement du plateau, Étalonage du XY, Étalonage du Z et Nivellement sur 9 points.

Procédez dans l'ordre suivant :

1. Cliquez sur [Outils] puis sur [Niveler et étalonner] sur l'écran tactile.
2. Sélectionnez le mode auxiliaire de nivellement et d'étalonnage.
3. Le capteur de l'extrudeuse a été étalonné en usine. Il n'est donc pas nécessaire de le refaire. Cliquez sur « Nivellement du plateau » et suivez les invites qui s'affichent.
4. Étalonnez l'axe Z et suivez les invites qui s'affichent.
5. Les axes X et Y ont été étalonnés en usine. Il n'est donc pas nécessaire de les réétalonner.
6. Le nivellement et l'étalonnage sont terminés.



Fonction de nivellement sur 9 points : si après le nivellement de la plateforme et l'étalonnage des axes X, Y et Z la planéité est encore imparfaite, vous pouvez utiliser cette fonction pour l'améliorer.



Mode de nivellement manuel : Exécutez successivement le nivellement de la plateforme, l'étalonnage de l'axe Z et celui des axes X et Y. C'est un ensemble complet de procédures de nivellement et d'étalonnage.

Première impression

Avant la première impression, veuillez achever le calibrage, calibration et chargement du filament correctement.

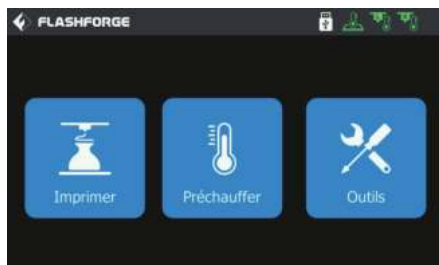

1. Cliquez sur Imprimer.



2. Appuyez sur mémoire locale pour choisir les fichiers d'impression.

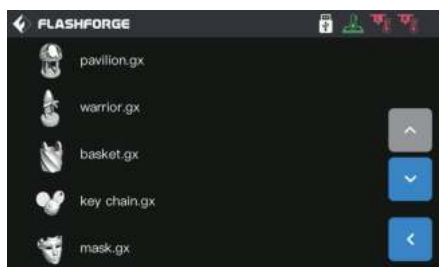

3. Sélectionnez le fichier.



4. Cliquez sur Imprimer.

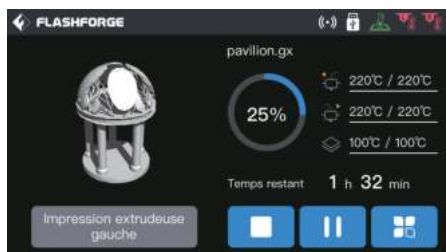

5. L'imprimante commencera à imprimer une fois le chauffage terminé.

Creator 3 Pro 빠른 가이드

크리에이터 프로3 소개

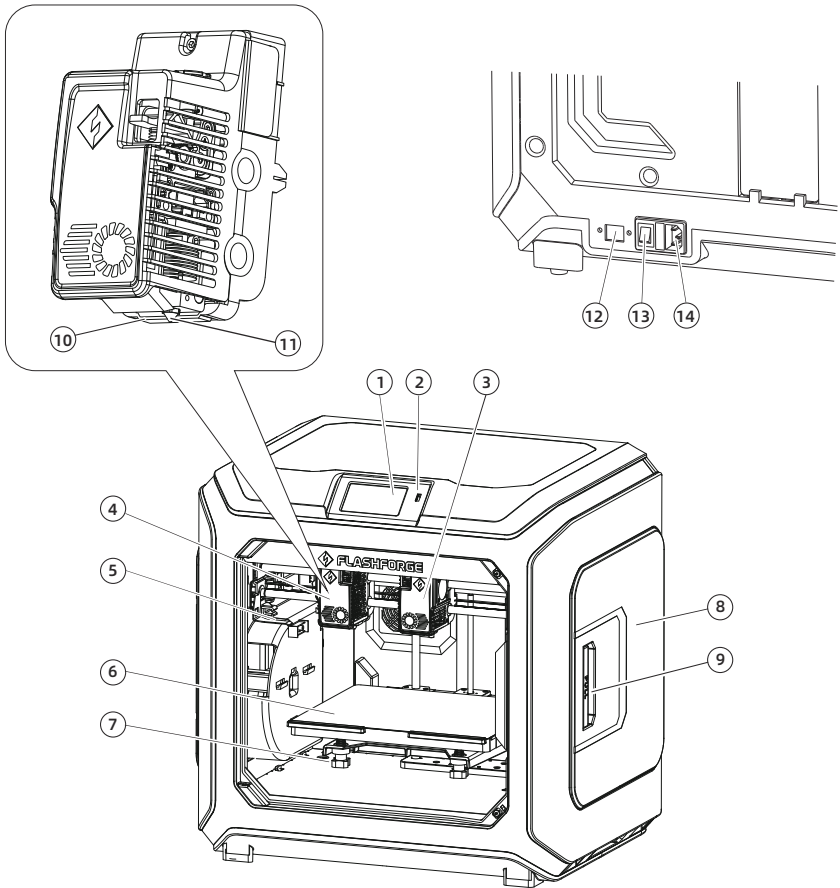

- | | | | |
|---------------|---------------|------------------|--------------|
| 1. 터치 스크린 | 5. 침투방지판 | 9. 필라멘트 홀드 커버 핸들 | 13. 전원 스위치 |
| 2. USB 디스크 포트 | 6. 빌드 플레이트 | 10. 윈드 가이드 노즐 | 14. 전원코드 엔트리 |
| 3. 오른쪽 익스트루더 | 7. 레벨링 너트 | 11. 노즐 | |
| 4. 왼쪽 익스트루더 | 8. 필라멘트 홀드 커버 | 12. 이더넷 포트 | |

포장물 리스트

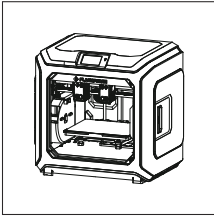

크리에이터3 프로

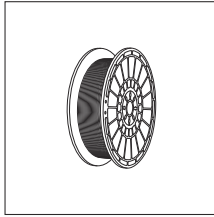

필라멘트

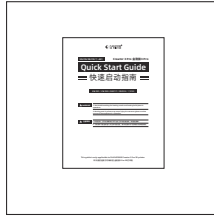

빠른 가이드



애프터 서비스 카드

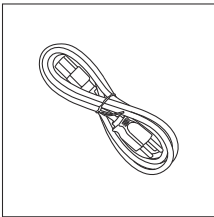

전원 코드

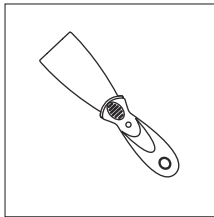

스크래퍼

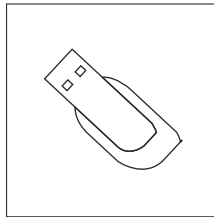

USB 디스크

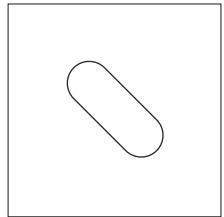

레벨링 카드

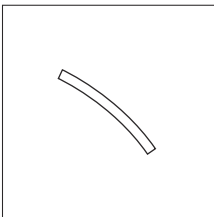

PTFE 튜브

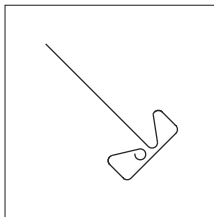

막힘뚫기 핀

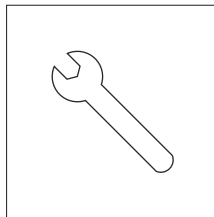

스텝핑 렌치

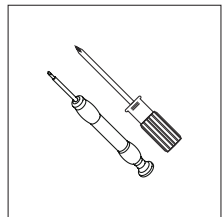

드라이버

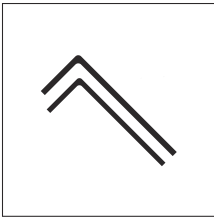

앨런 렌치

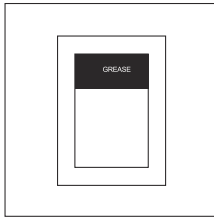

윤활 그리스

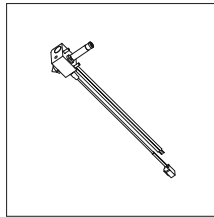

노즐 어셈블리

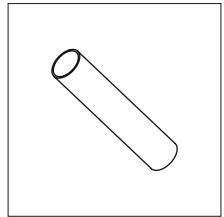

노즐 지지판

장비 언박싱 주의사항

1. 상부의 액세서리와 펠-면직물을 꺼냅니다.
2. 기계에서 테이프를 제거합니다.
3. 내부의 펠-면직물 블록을 꺼냅니다.

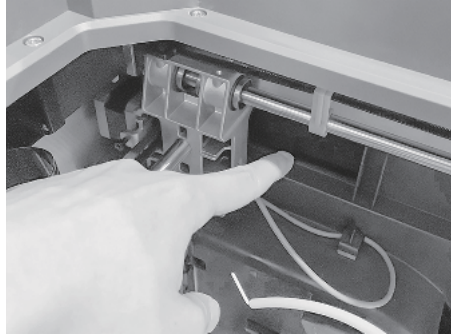
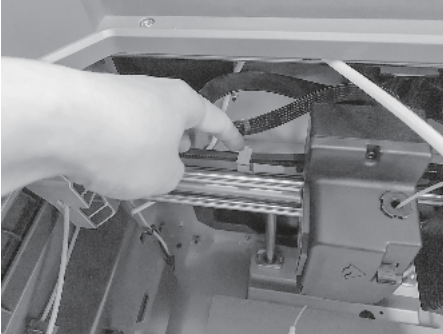

4. X-축과 Y-축 동기화 벨트의 버클을 제거합니다.



5. 프린터를 전원에 연결하고, 전원을 켜 후 터치스크린에서 [공구]와 [수동 조작]을 차례로 클릭하여 수동 제어 인터페이스로 들어갑니다.



6. 빌드 플레이트가 더 높은 위치로 올라갈 때까지 [Z-]를 계속 누르고 있다가 아래의 폼 블록을 꺼냅니다.

프린팅 준비하기

필라멘트로딩

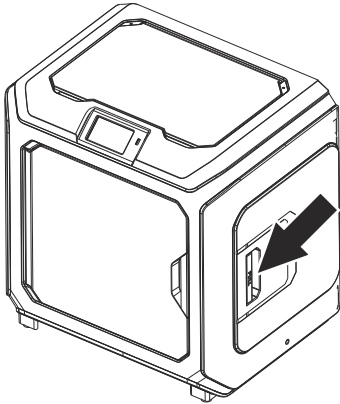

1. 필라멘트 홀더 커버를 엽니다.

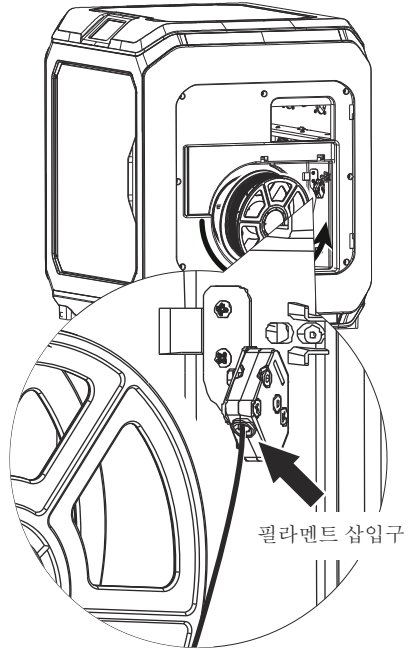

2. 필라멘트를 잡아서 필라멘트 투입구에 삽입합니다.

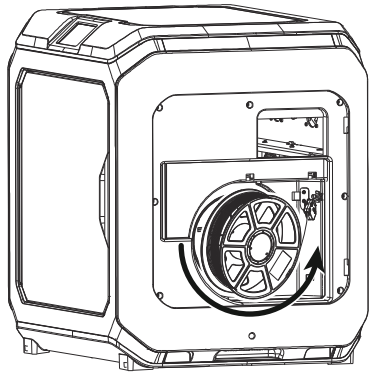
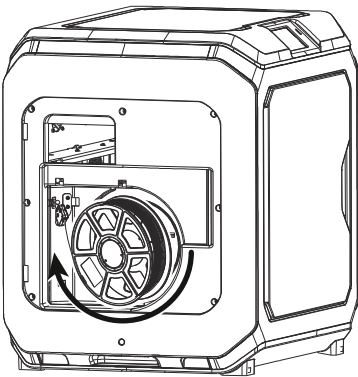

3. 주의: 필라멘트의 원활한 회전을 위해 필라멘트를 그림과 같은 방향으로 설치하여 주십시오.

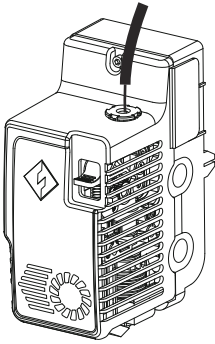

4. 필라멘트가 필라멘트 가이드 튜브를 통과할 때까지 필라멘트 투입구에 필라멘트를 연속적으로 삽입합니다.

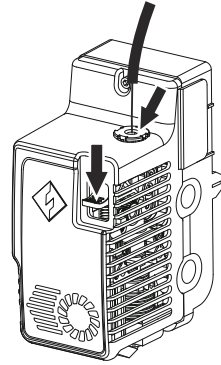

5. Extruder 전면의 필라멘트 이송 누름판을 누르고 더 이상 삽입되지 않을 때까지 필라멘트를 Extruder에 수직으로 삽입한 후 필라멘트 이송 누름판에서 손을 뗍니다.

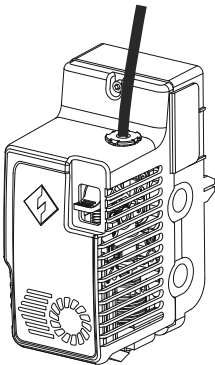

6. 필라멘트 가이드 튜브를 Extruder의 필라멘트 주입구에 삽입하여 고정합니다.

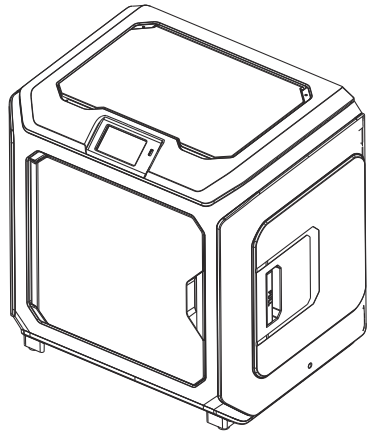

7. 마지막으로 필라멘트 스푼 홀더에 필라멘트를 고정하고 커버를 닫습니다.



8. 필라멘트 피딩 작업: 화면의 [공구]-[필라멘트] 버튼을 차례로 클릭하고, 필요한 재료 온도 값에 따라 적절한 가열 온도를 설정합니다. 화면 지시에 따라 조작하고 노즐이 균일한 필라멘트를 부드럽게 압출할 때까지 기다립니다.

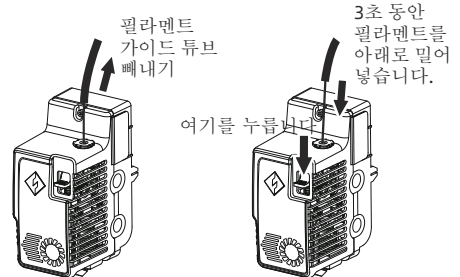
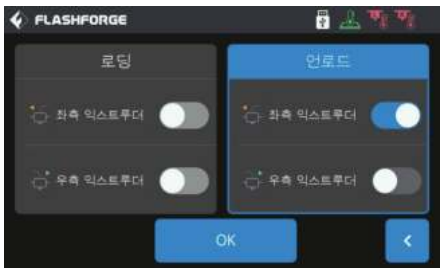

필라멘트 언로딩 작업: [언로드]를 클릭하고 Extruder 온도 가열이 완료된 후 필라멘트 누름판을 아래로 누르고 흰색 필라멘트 가이드 튜브를 당겨 빼낸 후 Filament를 재빨리 위로 잡아당기면 필라멘트 언로딩이 완료됩니다.

레벨링과 보정

이 장비는 공장을 떠나기 전에 수평을 맞추고 보정되었습니다. 단, 운송 중 발생하는 진동에 의해 수평면이 훼손될 수 있습니다. 첫 번째 인쇄 전에 레벨링을 수행하는 것이 좋습니다. 보조 레벨링 모드와 수동 레벨링 모드의 두 가지 레벨링 모드가 있습니다. 보조 레벨링 모드에서는 압출기 센서와 보조 프롭프트의 도움으로 모든 실행이 완료됩니다. 기능 옵션이 수동 모드일 때 보조 모드에서 플랫폼 수평 조절은 센서 기능을 활성화하지 않습니다.

전체적으로 장비에는 플랫폼 레벨링, 보정 XY, 보정 Z 및 자동 레벨링과 같은 레벨링 보정이 포함됩니다.

다음 순서로 작동하십시오.

1. 터치 스크린에서 [공구] 및 [레벨]을 클릭합니다.
2. 레벨링 및 보정을 위한 보조 모드를 선택합니다.
3. 압출기 센서 보정은 출고 전에 설정되었으므로 다시 작동할 필요가 없습니다. 플랫폼 레벨링을 클릭하고 화면의 지시에 따라 작동합니다.
4. Z축 보정을 수행하고 화면의 지시에 따라 작동합니다.
5. X, Y 축은 출고 전에 보정되었으므로 다시 확인할 필요가 없습니다.
6. 전체 레벨링 및 보정이 완료되었습니다.



9 포인트 레벨링 기능: 플랫폼 레벨링 및 XY/Z 축 보정 후에도 인쇄 평탄도가 여전히 불량할 때 이 기능을 사용하여 더 나은 평탄도를 보정할 수 있습니다.



수동 레벨링 모드: 플랫폼 레벨링, Z축 보정 및 X, Y축 보정을 차례로 실행합니다. 이것은 레벨링 및 보정 작업 절차에서 필요한 모든 절차입니다.

첫 출력 하기

첫 출력 전에는 반드시 설명서를 따라 레벨링 및 캘리브레이션 작업을 진행해 주세요.



1. [출력] 버튼을 누릅니다.



2. 출력을 위해 내장 메모리 화면을 선택합니다.

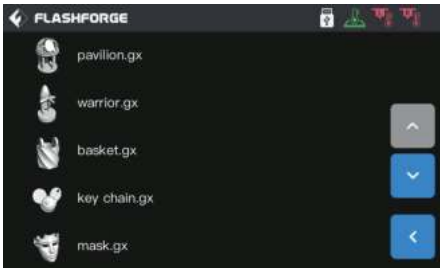

3. 내장된 테스트 파일을 선택합니다.



4. 출력 버튼을 클릭합니다.

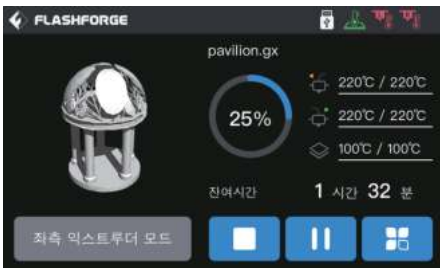

5. 노즐이 가열되고 나면 출력 작업이 진행됩니다.



Follow us

Zhejiang Flashforge 3D Technology Co., Ltd.

Address: No.518 XianYuan Road, Jinhua City, Zhejiang Province, China

Service Hotline: +86 579 82273989

support@flashforge.com